

This document shall be issued upon changes to the design of a GCT Product.
It shall be distributed to all Interested Parties and shall be made available on the GCT Website.

Date of Notice: (DD/MM/YYYY) **15/02/2023** Product Change Notice Number: **USB4160 A2 PCN 20230215**

Product Identifier: **USB4160-03-XXXX-C**

Drawing Revision Letter: **A2** Effective from date code/batch code: **Immediate**

Description of Changes: with diagrams if relevant

1. Slight change to recommended PCB layout

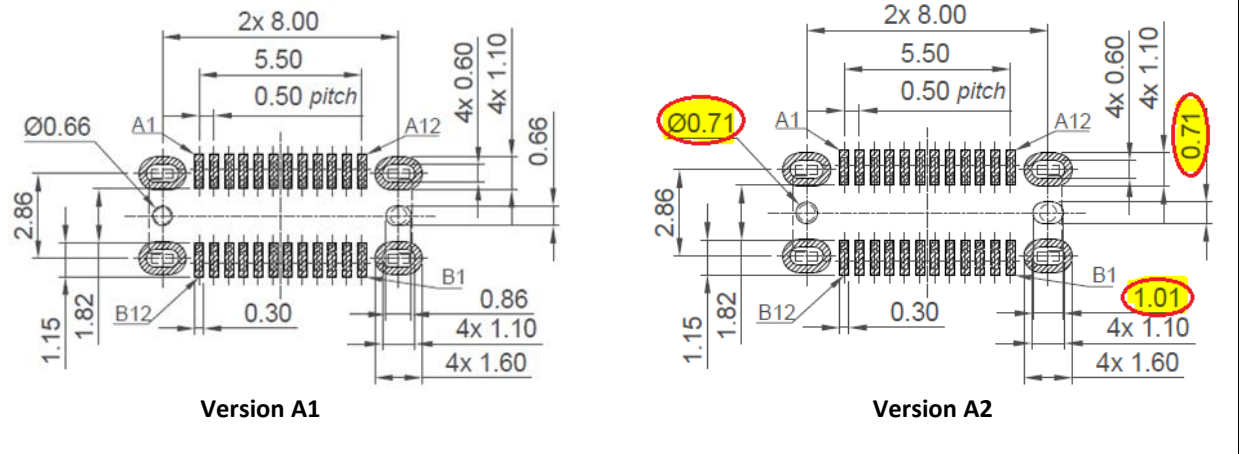

Reason for Change:

Updated recommended PCB layout to accommodate reliable pick and placement

Anticipated Impact on Form, Fit, Function or Reliability:

None, there is no impact on form, fit, function or reliability

Required Inventory Action:

None

Contact Information(s): (if blank, please visit www.gct.co or use the regional details below).

GCT Europe (UK) +44 (0)1707 321122 sales@gct-europe.com	GCT Americas (USA) +1 978 208 1618 sales@gct-americas.com	GCT Asia-Pacific (HK) +852 2578 9030 sales@gct-apac.com
---------------------------------------------------------------	-----------------------------------------------------------------	---------------------------------------------------------------